

# DC Circuits and Thevenin's Theorem

## PRE-LAB

Review sections 4.7 – 4.10 of Purcell. Make sure you know the distinction between series and parallel circuits. Record the expressions for the equivalent resistance of series combinations and parallel combinations of resistors in your lab notebook. Also, make sure you are familiar with the idea of a Thevenin equivalent circuit.

**Pre-lab Question 1: The lab power supplies can provide a maximum of 30 V and 1A to a circuit. If you use a 2200  $\Omega$  resistor with a power rating of 0.5 W, do you need to worry about exceeding the power rating? Explain.**

**Pre-lab Question 2: For the circuit given in Figure 3, what is the current through  $R_3$ ?**

**Pre-lab Question 3: If all internal EMFs are shorted, what is the equivalent resistance,  $R_{eq}$  for the circuit in Figure 3?**

## INTRODUCTION

In class, you have learned about the behavior of resistors in direct current circuits. This included both series and parallel combinations of resistors. Most electrical circuits encountered in a lab setting are more complicated. Therefore, you will explore the behavior of a network of multiple resistors and voltage sources.

Suppose a complicated circuit is in a box with only two external terminals. The only information you can get about this circuit is the voltage (potential difference) across the terminals and the current between the terminals when shorted together. Thevenin's theorem states that the circuit in this box, no matter how complicated, behaves identically to a single voltage source,  $\mathcal{E}_{eq}$ , in series with a single resistance,  $R_{eq}$ .

Today, you will put Thevenin's theory to the test. First, a network of resistors and voltage sources is analyzed. Then you will build a circuit with  $\mathcal{E}_{eq}$  and  $R_{eq}$  to test if it behaves identically to the complicated circuit.

## EXPERIMENTS

You will build the circuit on an electronics breadboard. All the holes along a row of the breadboard are in electrical contact, as shown in Figure 1. Before beginning, take a moment to study the breadboard on which you will build your circuits. Confirm which holes are in electrical contact with one another using your multimeter.

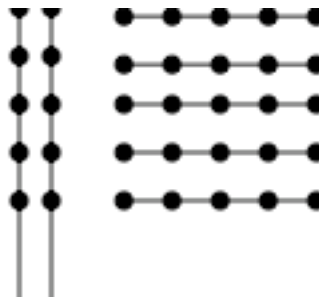

Figure 1. Typical connections on electronics breadboard.

## Experiment 1: Parallel Resistor Circuit

In this experiment you will construct the circuit shown in Figure 2 and study its behavior. You should proceed as follows:

- Measure the resistances  $R_1$  and  $R_2$  of your two resistors with the precision meter or with your multimeter in the  $\Omega$ (ohms) mode.
- Connect the resistors in the proper configuration for the parallel circuit diagrammed in Figure 2; Do NOT connect the power supply yet.
- Calculate the equivalent resistance of  $R_1$  and  $R_2$  in parallel. Verify this value using the multimeter. **Do they agree?**
- Switch your multimeter to  $\ddot{V}$  (DC volts) and connect the power supply to the circuit. (The ammeter has not yet been connected into the circuit.) Turn on the power supply and record the value of  $\epsilon_0$  (the emf of the power supply).
- Before measuring the currents, calculate the total current  $I$  being drawn from the power supply. Then calculate the separate branch currents  $I_1$  and  $I_2$ . Because the branches “divide” the current into two parts, this circuit is called a “current divider”.
- Turn off the power supply and connect the multimeter into the circuit so that it serves as the ammeter as in Figure 2 and measures the total current  $I$ . Switch the meter to  $\ddot{A}$  (DC amps), move where the “hot” lead connects to the multimeter, turn the power supply back on, and record the current. Turn off the power supply again, and re-connect the multimeter in the circuit so that you can measure just the current through  $R_1$ . Turn on the power supply and measure  $I_1$ . Repeat for  $R_2$ . (Getting the ammeter connected so that you actually measure what you intend to measure can be tricky. Try drawing a circuit diagram for each configuration. Then try wiring up the circuit to look **exactly** like the diagram.)
  - Does  $I = I_1 + I_2$ , within uncertainty?

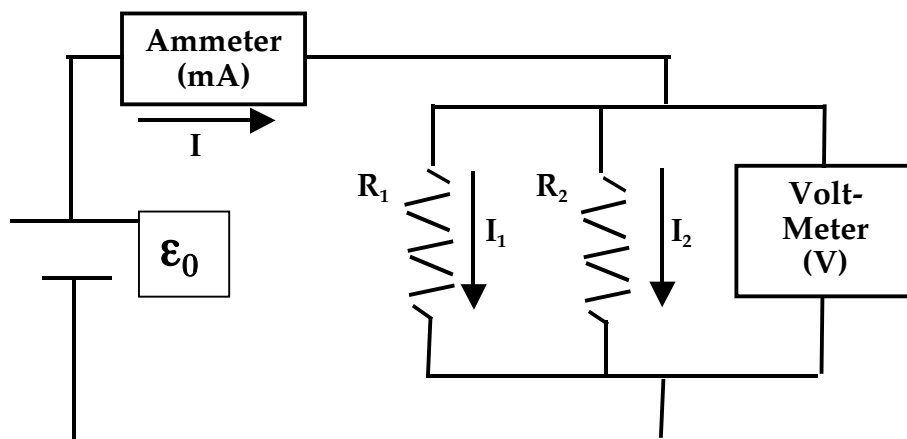

Figure 2. Parallel Resistor Circuit.

## Experiment 2: Resistor-Voltage Source Network

At your lab station, you have all the equipment needed to construct the circuit in Figure 3.

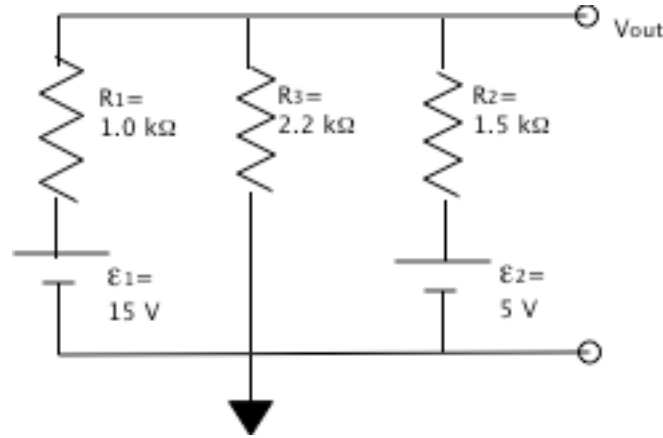

Figure 3. Resistor network with two voltage sources.

The resistors do not have exactly the resistance stated, so you first need to measure the actual resistances. The measurement uncertainty of the multimeter is 1% for resistance. Now, calculate the theoretical equivalent resistance,  $R_{eq}$ , based on your actual resistance values. Formally calculating the uncertainty in  $R_{eq}$  is extremely tedious. A very good approximation can be made by saying the percent uncertainty of the denominator in Equation 1 is 1%. (You can verify this using the general error propagation formula.)

$$R_{eq} = \frac{R_1 R_2 R_3}{R_1 R_2 + R_2 R_3 + R_1 R_3} \quad (1)$$

Now, you should be able to find the absolute uncertainty of  $R_{eq}$  fairly easily.

Build the circuit shown in Figure 3. Make sure that the “Ground” or “Common” sides of both voltage sources are connected to one another on the breadboard. Measure  $\Delta V_{out}$  (the potential difference across the two terminals marked with open circles in figure 3) and record this value with its uncertainty. Next measure the short circuit current,  $I_{sc}$ , that flows if the two terminals are shorted together (think about how to connect the meter to accomplish this). Remember that you need to move the “hot” lead connection on the multimeter in order to measure current. Record  $I_{sc}$  and its uncertainty.

Use Ohm’s law to calculate an experimental value for  $R_{eq}$ . (Yes, of course you need to find the uncertainty!)

- **How does this value compare with the theoretical equivalent resistance you found?**
- **More than likely, the two values don’t agree. What other sources of resistance might be present in your circuit? How might you test for them?**

Next, attach a  $1.0\text{ k}\Omega$  load resistor across the output terminals of the circuit and measure  $V_{\text{load}}$  across the resistor. Repeat the measurement with a load resistance of  $100\ \Omega$ .

### Experiment 3: Thevenin Equivalent Circuit

Build the Thevenin equivalent circuit shown in Figure 4 using the experimental  $\mathcal{E}_{\text{eq}}$  and  $R_{\text{eq}}$  from the circuit in Experiment 2. You now need only one voltage source, but you will probably need to use a combination of resistors in series to obtain  $R_{\text{eq}}$ . The instructor has a variety of resistors from which to choose. Since you will probably not be able to get an exact match for the total resistance, be sure to assign a reasonable value of uncertainty to  $R_{\text{eq}}$ .

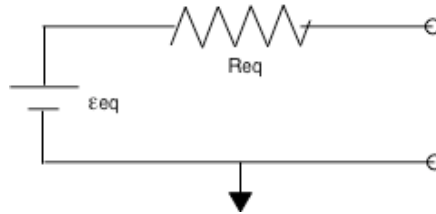

Figure 4. Thevenin Equivalent Circuit.

With the multimeter, measure  $V_{\text{out}}$  as in Experiment 2 and the current through the circuit.

- **Do these measurements agree with those from the original circuit?**

Attach the  $1.0\text{ k}\Omega$  load resistor across the output of the circuit and measure  $V_{\text{load}}$  across the resistor. Repeat the measurement with a load resistance of  $100\ \Omega$ .

- **Do these measurements agree with the measurements from the original circuit?**
- **Are the two circuits really equivalent? If the circuits were both enclosed in a “black box”, would you be able to tell them apart based on your measurements?**
- **Consider the power supplies that you used as voltage sources. Are they examples of a Thevenin “black box”? In what ways are they similar or different from such a “black box”?**

### LAB BOOK CHECKLIST

You should have:

- Data that verify the expression for adding resistors in parallel as well as the expression for a current divider.
- Circuit diagrams and other apparatus notes.
- Measured values for all resistances, voltages, and currents with uncertainties.
- Theoretical and experimental values for the Thevenin  $R_{\text{eq}}$  with uncertainties.
- Discussion of questions in bold type.